

# MINI-VERTICUS & VERTICUS THE NEXT GENERATION

INDUSTRIAL COMPRESSORS FOR AIR, NITROGEN AND RARE GASES



## MINI-VERTICUS & VERTICUS

### STATIONARY COMPRESSORS – REINVENTED

The new MINI-VERTICUS & VERTICUS Series set the standards of the future for stationary high-pressure compressor systems. The series combines the quality and reliability of the preceding stationary compressor series with an all-new design, B-APP smartphone connection, online air quality monitoring and outstanding ergonomic features.

The new, extremely compact MINI-VERTICUS benefits particularly from BAUER's signature design: numerous accessory models from the larger VERTICUS series, such as the B-CONTROL II control unit, are now also available for the MINI-VERTICUS.

The system optionally supports remote-control operation and control with the B-APP. With an ultra-reliable, high-precision smart internal online measurement system that monitors compliance with toxin limit values<sup>1</sup> in the air and automatically shuts down the system in case of doubt.

With significantly lower-noise operation, outstanding ergonomic design and unparalleled user-friendliness.

- › 30 to 525 bar
- › 85 to 800 l/min
- › Available with open or soundproofed housing
- › For air, nitrogen and rare gases
- › Compressor or booster version

<sup>1</sup> ISO 8573:2010 compliant.

Measurement of humidity and oil (VOC) as option. Oil measurement based only on volatile organic compounds (VOCs). Sensor calibration based on isobutene.



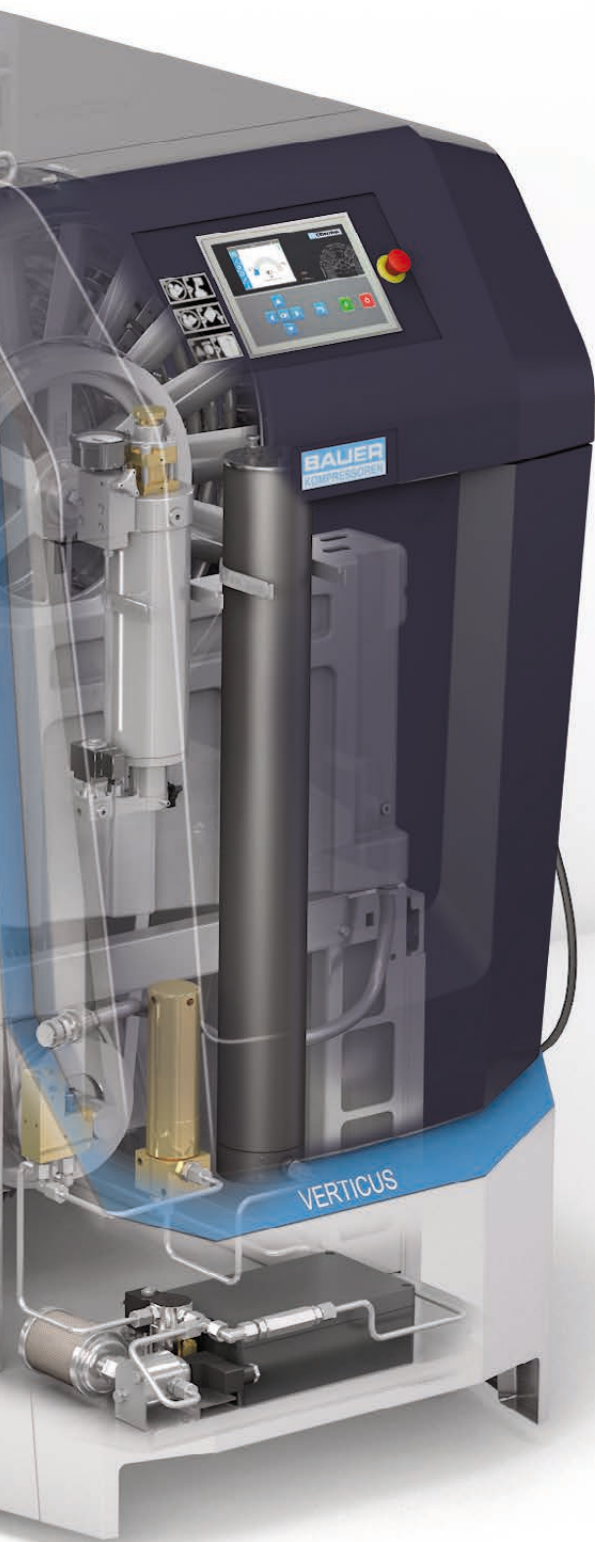

## ICONIC DESIGN

The groundbreaking design sets new standards. The sleek, bold lines of the new VERTICUS systems express their status as technology leaders in the field of stationary high-pressure compressors.



## ERGONOMIC

All the main operating elements and displays are conveniently located on the front for maximum ease of access and viewing. The front panel can be opened with a single movement to change the filter cartridge rapidly and conveniently.



## EVEN QUIETER

The sophisticated soundproofing concept has reduced the already low noise level still further. The motor is suspended in an optimised anti-vibration frame and incorporates a new type of high-efficiency hydro-damping system.



## SMARTPHONE INTERACTION

The new B-APP is used with B-CONTROL to transform your smartphone into an advanced compressor remote control unit.



## CONTINUOUS AIR MONITORING

B-DETECTION PLUS is the new fully integrated gas measurement system that monitors the quality of the compressed breathing air. Automatic, continuous and outstandingly reliable.

# SETTING NEW STANDARDS FOR STATIONARY COMPRESSORS

IN A CLASS OF ITS OWN FOR DESIGN, ERGONOMICS AND FUNCTION



“Form follows function”, the famous principle of modern architecture, was our watchword for the development of the new design. It is reflected in even the tiniest detail.

All the main operating elements and displays are conveniently located for maximum ease of access and viewing.

The top front panel with the control unit can be raised for immediate access to the filter, so that changing the cartridge is simple and fast. As a further benefit, the filter housing is now located in the colder front area of the system and thus offers significantly extended cartridge life. The control unit is on the side of the system, likewise providing optimum cooling. The control panel can be fully extended for maximum convenience in operation.

The condensate tank, now with 40 per cent higher capacity, is located in the interior of the housing. The control unit displays a warning before the maximum condensate level is reached. The tank is easily emptied using a service valve.

B-DRAIN automatic condensate drain system has also been completely redesigned. The new system ensures that oil/water condensate is extracted at minimum loss of pressure and low noise. This saves wear on pressurised parts, extends their service life and increases the F.A.D. rate.



## THE G-SERIES – SPECIALISTS IN HELIUM COMPRESSION

### GAS COMPRESSION AND RECOVERY WITH MAXIMUM EFFICIENCY

Helium is a rare and expensive gas. The MINI-VERTICUS & VERTICUS G Systems in extra gas-tight models deliver highly efficient recovery and filling of the rare gas, with an innovative and sophisticated high-pressure system technology that minimises gas loss.

The compressor block is designed specifically for rare gas processing and top efficiency. An array of design features effectively prevent leakage of the highly volatile gas, creating a closed gas cycle. The system features enclosed safety valves and gas-tight ferrule compression fittings on the high-pressure side. Gas from the crankcase ventilation system and the condensate valves is recovered and returned to the intake area.

The layout of the helium compression system is tailored to customers' needs. If required, the compressor, intake buffer tank and condensate reservoir can be supplied ex works as a turnkey plug-and-play solution, on a single shared base frame; alternatively, the components can be positioned on site to make the most of available space and assembled by BAUER's service team.

Helium can be used on request in final pre-delivery testing of these compressors.

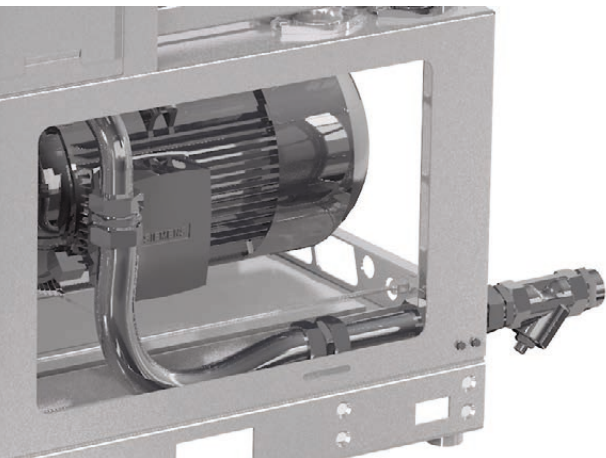

## THE NEW ACCESSORIES

### CUSTOMISING THE SYSTEM TO YOUR INDIVIDUAL NEEDS

The new MINI-VERTICUS & VERTICUS feature a wide range of accessories from standard models upwards.

However, we also offer you the opportunity to customise and extend your system in line with your individual requirements. Our comprehensive range of accessories opens up virtually unlimited possibilities.

For full details, see our separate “Accessories Brochure”.

- › **B-KOOL:** This fully integrated refrigeration dryer helps you to slash operating costs by significantly extending filter cartridge life. The purchase costs are soon recouped; from then onwards, you save money while helping to conserve the environment.
- › **P61/81 Purification Systems:** Depending on the application or filter cartridge type, these systems absorb, convert or extract moisture (H<sub>2</sub>O), oil and carbon monoxide (CO). Available as integrated or external systems.
- › **B-SECURUS Filter Cartridge Monitoring Unit:** Efficiently monitors filter cartridge saturation.
- › **Particle Filter:** An integrated particle filter is available for use in conjunction with P61 and P81 Purification Systems, ensuring effective protection against particle matter and offering reliable particle extraction that complies with ISO 8573 Class 2 standards.
- › **B-DETECTION PLUS s:** The new gas measurement system is also available with the same range of features as the B-DETECTION PLUS i as a standalone model for retrofitting.
- › **Oil Level Monitoring Function:** The optional oil level monitoring function effectively prevents damage to the compressor caused by excessively low oil levels. The function shuts down the system in time to avert damage and flashes a warning in the control unit display. Recommended for compressor systems in permanent operation.



## TECHNICAL DATA



Model number	F.A.D. <sup>1</sup>			Max. operating pressure <sup>2</sup>		No. stages	Speed	Motor-output	Power-consumption <sup>1</sup>	Net weight approx.		Dimensions L x W x H
	l/min	m <sup>3</sup> /h	cfm	bar	psig					kg	lbs	
<b>MINI-VERTICUS 90 - 365 bar</b>												
I 100-3-MV	85	5.1	3	365	5300	3	900	3	2.2	250	560	120 x 81 x 138
I 100-4-MV	125	7.5	4.4	365	5300	3	1270	4	3.3	255	560	120 x 81 x 138
I 120-4-MV	170	10.2	6	365	5300	3	1200	4	3.7	260	570	120 x 81 x 138
I 120-5.5-MV	215	12.9	7.6	365	5300	3	1470	5.5	4.7	260	570	120 x 81 x 138
I 12.14-7.5-MV <sup>3</sup>	300	18	10.6	365	5300	4	1450	7.5	6.5	310	680	120 x 81 x 138
<b>VERTICUS 90 - 365 bar</b>												
I 15.1-7.5-V	340	20.4	12	365	5300	4	1050	7.5	6.9	340	750	120 x 81 x 153
I 15.1-11-V	420	25.2	15	365	5300	4	1320	11	9.6	350	770	120 x 81 x 153
I 150-11-V	500	30	18	365	5300	4	1230	11	10.2	350	770	120 x 81 x 153
I 180-15-V	610	36.6	21	365	5300	4	1320	15	12.0	365	805	120 x 81 x 153
<b>VERTICUS 350 - 420 bar</b>												
I 15.11-7.5-V	310	18.6	11	420	6100	4	960	7.5	7.0	350	770	120 x 81 x 153
I 15.11-11-V	420	25.2	15	420	6100	4	1320	11	10.4	360	790	120 x 81 x 153
I 18.1-15-V	515	30.9	18,2	420	6100	5	1490	15	13.0	375	825	120 x 81 x 153
<b>VERTICUS 420 - 525 bar</b>												
I 15.11-7.5-V	310	18.6	11	525	7600	4	960	7.5	7.0	350	770	120 x 81 x 153
I 15.11-11-V	420	25.2	15	525	7600	4	1320	11	10.4	360	790	120 x 81 x 153
I 18.1-15-V	510	30.6	18	525	7600	5	1490	15	13.5	375	825	120 x 81 x 153

1 Volume flow rate in accordance with ISO 1217, power consumption given for maximum final pressure under defined framework conditions. Different ambient conditions will result in differing performance values. Values are valid for 50 Hz.

2 Max. operating pressure = max. pressure setting for safety valve; shutdown pressure is lower.

3 Not suitable for nitrogen.

## TECHNICAL DATA

AIR N<sub>2</sub>

Model number	F.A.D. <sup>1</sup>			Max. operating pressure <sup>2</sup>		No. stages	Speed	Motor-output	Power-consumption <sup>1</sup>	Net weight approx.		Dimensions L x W x H
	l/min	m <sup>3</sup> /h	cfm	bar	psig					kg	lbs	
<b>MINI-VERTICUS 30 - 68 bar</b>												
B 12.4-4-MV	215	13	7.6	68	1000	3	1420	4	3.5	250	550	120 x 81 x 138
<b>MINI-VERTICUS 63 - 85 bar</b>												
E 12.4-3-MV	170	10,2	6	85	1230	3	1150	3	2.7	245	540	120 x 81 x 138
E 12.4-4-MV	215	13	7.6	85	1230	3	1420	4	3.7	250	550	120 x 81 x 138
<b>MINI-VERTICUS 75 - 100 bar</b>												
E 120-4-MV	215	13	7.6	100	1450	3	1420	4	3.7	250	550	120 x 81 x 138

1 Volume flow rate in accordance with ISO 1217, power consumption given for maximum final pressure under defined framework conditions. Different ambient conditions will result in differing performance values. Values are valid for 50 Hz.

2 Max. operating pressure = max. pressure setting for safety valve; shutdown pressure is lower.

HE

Model number	F.A.D. <sup>1</sup>			Max. operating pressure <sup>2</sup>		No. stages	Speed	Motor-output	Power-consumption <sup>1</sup>	Net weight approx.		Dimensions L x W x H
	l/min	m <sup>3</sup> /h	cfm	bar	psig					kg	lbs	
<b>MINI-VERTICUS 90 - 230 bar</b>												
G 100-3-MV	70	4.2	7.6	230	3350	3	900	4	2.1	535	1180	235 x 102 x 150
G 120-4-MV	105	6.3	6	230	3350	3	900	3	2.7	540	1190	235 x 102 x 150
G 120-5.5-MV	140	8.4	7.6	230	3350	3	1420	5.5	3.8	555	1220	235 x 102 x 150
<b>VERTICUS 90/150 - 350 bar</b>												
G 15.1-7.5-V	240	14.4	8.5	350	5100	4	880	7.5	6.3	620	1360	235 x 102 x 167
G 15.1-11-V	320	19.2	11.3	350	5100	4	1230	11	9.1	650	1430	235 x 102 x 167
G 18.1-15-V	420	25.2	14.8	350	5100	5	1490	15	13.3	670	1470	235 x 102 x 167

1 Volume flow rate in accordance with ISO 1217, power consumption given for maximum final pressure under defined framework conditions, valid for helium. Different ambient conditions will result in differing performance values. Values are valid for 50 Hz.

2 Max. operating pressure = max. pressure setting for safety valve; shutdown pressure is lower.

## BAUER KOMPRESSOREN GmbH

Stäblistr. 8

81477 München

Tel. +49 (0) 89 78049-0

Fax +49 (0) 89 78049-167

info@bauer-kompressoren.de

bauer-kompressoren.de



## MINI-VERTICUS &amp; VERTICUS IND EN

N42254

03.2017

Subject to technical change without notice